

SPECIFICATIONS

Dimensions: 206 x 67 cm  
 Weight: 106 kg  
 Height adjustment: ± 47 – 97 cm  
 Lifting capacity: Max. 200 kg  
 Mains voltage: 100 - 240 VAC, 50 - 60 Hz  
 Current: Max. 3.0 A  
 Standby power consumption: Max. 3 W  
 Insulation: Class II  
 Device Classification I  
 Applied parts Type BF  
 Humidity proof: IP22

Motor force: 8 kN  
 Motor usage: Max. 2 minutes/ 18 minutes off  
 Hydraulic pump: 10 kN  
 Frame material: Steel frames  
 Frame finish: Powder coated white RAL 9016  
 Conformity: IEC/EN 60601-1:2013 ed. 3.1  
 IEC/EN 60601-2: 2015 ed. 4.0  
 93/42/EEC  
 WEEE  
 RoHS2

Warranty: Table 1 year,  
 Premium upholstery 1 year,  
 Classique upholstery 1 year

FUNCTIONALITY/ DIMENSIONS

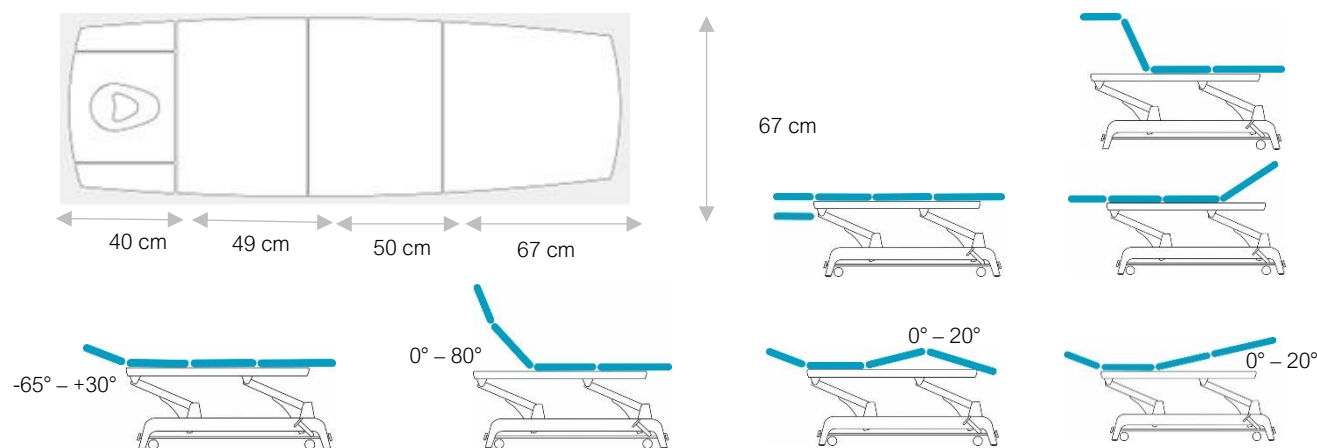

CUSHIONS UPHOLSTERY

Classique: PVC, phthalate free, biocompatible, abrasion resistant and flame retardant.  
 Premium: PU, phthalate free, biocompatible, abrasion resistant and flame retardant.

CUSHIONS FINISH

Linear: Single padded, 40 kg/m<sup>3</sup>  
 Progressive: Dual padded, 100 kg/m<sup>3</sup> and 40 kg/m<sup>3</sup>

OPTIONS

Ergomax: PU foam, closed skin, low density 5° Shore  
 Cushion heating: 34 °C, 36 °C and 38 °C  
 Bluetooth wireless operation  
 Automatic timer 30 minutes  
 Maximum consumption = 180 W  
 Battery function: Li-ion 25,9 VDC, 2,25 Ah

Memory function: Three programmable settings for height adjustment  
 Bluetooth wireless operation  
 LED Pack: Chassis illumination 14 colours, including brightness control  
 Power consumption = 10 W  
 Safe Motion Detection: Power consumption = 1 W